

Special Applications



Possibilità di personalizzazione

Linee complete chiavi in mano – Servizio Progettazione interno
 Multihead e Multifiller
 Etichettatura e trasferimento termico
 Nastri in out personalizzabili
 Allineatori
 Disimpilatori vaschette singoli o multiformato
 Film stampato



Customized Italianpack Project

Multihead and Multifiller
 Labelling and thermal transfer
 Conveyor in – out customized
 Inliner
 Denester for single or multi line
 Printed film



Ci riserviamo il diritto di modificare e migliorare le macchine senza nessun preavviso / We reserve the right to improve our machines without warning - ed. 05/2015

Italian Pack



Italian Pack

Italian Pack Srl
 Via al Bassone, 30, 22100 - **COMO** - Italy

☎ (+39) 031.888.011
 ☎ (+39) 031.888.050

✉ sales@italianpack.it
 🌐 www.italianpack.com



PERSEUS product line

Packaging Machines Since 1988

Specifiche tecniche Technical Specifications

✓ Standard
 ● Optional
 ✗ Non disponibile - Not available

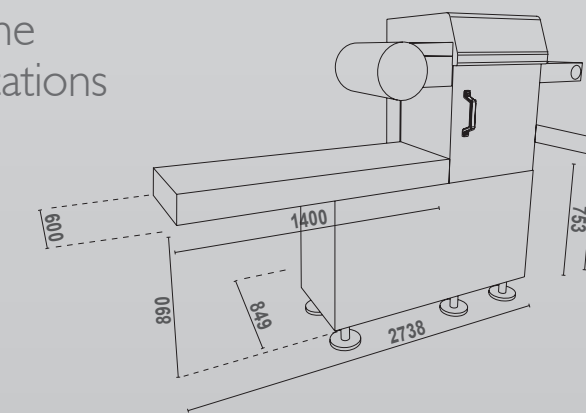

Dimensioni macchina (mm, P/L/H) Machine dimensions (mm, P/L/H)	440
Peso (kg) Weight (kg)	440
Carrozzeria in Frame made of	acciaio inox stainless steel
Alimentazione elettrica (standard) Electrical supply (standard)	3 x 400 V + N + PE - 50 Hz
Potenza assorbita (kW) configurazione standard Power supplied (kW) in standard configuration	2,1 -> 3,9
Aria compressa richiesta (bar) Compressed air (bar)	6/8
Pompa alto vuoto lubrificata (m ³ /h) Lubricated high vacuum pump (m ³ /h)	✓ 63 ● 100 / 200 / 300
Massima fascia bobina film (mm) Maximum reel film width (mm)	480
Massimo diametro esterno bobina film (mm) Max reel film diameter (mm)	240

Massima dimensione vaschette (mm) Maximum trays dimension (mm)	n°1 400x275	n°2 185x275 H max 110	n°3 120x275 H max 110	n°4 85x275 optional 160
---	-------------	--------------------------	--------------------------	----------------------------

OPTIONAL Massima dimensione vaschette (mm) Maximum trays dimension (mm)	n°2 193x275 H max 110	n°3 137x275 H max 110
--	--------------------------	--------------------------

Avanzamento e riavvolgimento automatico film Automatic film feeding and rewinding	✓
Nastro alimentazione vaschette (mm) Tray feeding conveyor (mm)	1400
Gestione macchina Operating system	PLC con sensore digitale integrato PLC with integrated vacuum sensor
Numero cicli macchina Cycle/min	5/15
Versione PACK (senza tecnologia SOTTOVUOTO) PACK version (NO-VACUUM technology)	●
Aria compressa richiesta Compressed AIR	6/8

Altre opzioni Other options

Fotocellula presenza vaschetta
Tray detection photocell
 Fotocellula centratura film stampato
Printed film registration
 Polmone gas
Gas buffer tank
 Dosatori prodotto liquido - solido
Dosing system (liquid and solid product)
 Disimpilatori di vaschette
Tray denester
 Marcatori data scadenza
Expiry date markers
 Nastro di scarico motorizzato con convogliatori per etichettatura
Motorized outfeed belt with optional labelling conveyor
 Filtro liquidi/polveri
Liquids/powders filter
 Cassetta cambio stampo
Mould changing wagon

La confezionatrice a fine linea può essere completata da: etichettatrice, pesatrice, applicatore coperchi preformati, ecc.
 The tray packaging machine can be completed with end of line functions: e.g. labelling machine, weighing machine, pre shaped lid applicator etc.



TECNOLOGIES

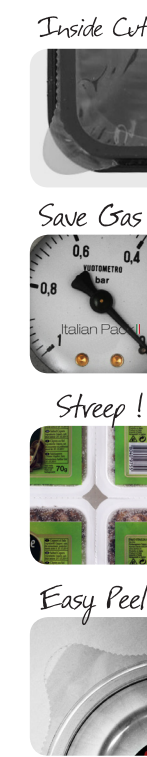

Inside Cut!

Save Gas!

Steep!

Easy Peel!



Skin technology è la soluzione perfetta per il confezionamento di prodotti freschi e surgelati. È ideale per carne, pesce, verdura e snacks.

Skin technology is a perfect solution to pack fresh and Frozen product. Especially ideal for meat, fish, vegetable and snacks.



Perseus

ItalianPack Perseus è una confezionatrice automatica di vaschette preformate in sottovuoto, MAP (vuoto+gas), TRAY SKIN e solo saldatura.

Oltre al modello Standard, "ItalianPack Perseus" può essere facilmente personalizzata e integrata con altri componenti per formare una "Linea Completa" chiavi in mano e fornire soluzioni a tutte le esigenze dell'industria moderna.

Il nostro Ufficio Progettazione Interno è disponibile per l'ingegnerizzazione di linee, di nastri in entrata e uscita, disimpilatori, bilance controllo peso, dosatori per prodotti liquidi o solidi, marcatori/ timbratori, allineatori ecc.

ItalianPack Perseus ha una capacità di confezionamento fino a 32 vaschette al minuto in MAP, 60 vaschette in solo saldatura e 28 in skin.

Il cambio stampo completo si effettua in meno di 2 minuti.

Tramite l'interfaccia Touch Screen si possono controllare tutti i parametri, memorizzare fino a 99 programmi e personalizzare la lingua di utilizzo.

Con lo stesso stampo è possibile confezionare in tutte le modalità: Saldatura, MAP e SKIN TRAY.

Il costo molto contenuto degli stampi permette una personalizzazione e varietà di formati senza precedenti.



Confezionatrici di vaschette in sottovuoto e atmosfera protettiva
Tray Heat Sealing machines with both vacuum and gas

Perseus is a fully automated machine for the vacuum, M.A.P. (vacuum+gas), skin tray and sealing packaging of pre-formed trays. In addition to our standard machine, "ItalianPack Perseus" can be tailored to customers' needs and additional components allow for a turnkey "complete line" to meet the requirements of today's food industry.

Our company's Engineering Department will assist you by designing and developing entire lines, infeed and outfeed conveyors, tray denesters, checkweighers, dosing machines for liquids and solids, markers/printing machines, aligning devices, etc.

ItalianPack Perseus can pack up to 32 M.A.P. trays per minute, 60 sealed trays and 28 skin trays. Die changing only takes less than 2 minutes. Our user-friendly touch screen displays allows easy monitoring of parameters, storage of up to 99 packaging programs and language selection. The same die allows for different types of packaging: film sealing, MAP and skin tray.

The moderate price of our dies makes it easy to custom-design our machines and to choose from an extensive spectrum of trays sizes.



PLC Touch wide screen 7.2" a 65,000 colori, porte USB/Ethernet, 99 programmi, personalizzazione della lingua, controllo temperatura integrato, gestione avanzata parametri MAP, Tray SKIN e graduata vacuum.

7.2" PLC Touch screen, 65,000 display colors, USB port/Ethernet, 99 packaging programs, language selection, integrated temperature control, menu-driven M.A.P. parameters, skin tray and gradual vacuum.



Quadro elettrico in acciaio inox 304 ad alto spessore, telaio con saldature a filo, contatti numerati, facilmente accessibile e sanificabile. Apertura tramite pannello inox incernierato.

AISI 304 stainless steel electric box, wire welded frame, numbered cables, ensures easy access for cleaning operations.



Cambio formato inferiore ai due minuti.
Tool change in less than 2 minutes.



Gruppi sigillatura, vuoto e catenaria accessibili istantaneamente dal vano porta per rapide ed agevoli operazioni di manutenzione e sanificazione.

Access to sealing, vacuum units and feeding chains through front door for quick and easy maintenance and cleaning operations.



Telaio realizzato su una solida struttura in acciaio inox.
Robust stainless steel frame.



Nastri di carico modulari adatti ad ogni tipo di personalizzazione e per integrazione con disimpilatori, dosatori o postazioni di carico.

Infeed conveyors available in different sizes, all suitable for any custom-designed system and for integration with tray denesters, dosing machines and loading positions.



Disimpilatori di vaschette da 1 a 6 piste, con possibilità di cambio rapido del formato.

Tray denester with up to 6 lines. Quick format change available.



Polmone gas in acciaio inox con regolatore di pressione.

Stainless steel gas buffer tank with pressure regulator.



Caricamento automatico di vaschette da 1 a più piste con nastro a 90° oppure con nastro in linea da 1 a 2 piste.

Automatic tray infeed system with a 90 degree conveyor from 1 to several tray lines or an in-line conveyor from 1 to 2 tray lines.

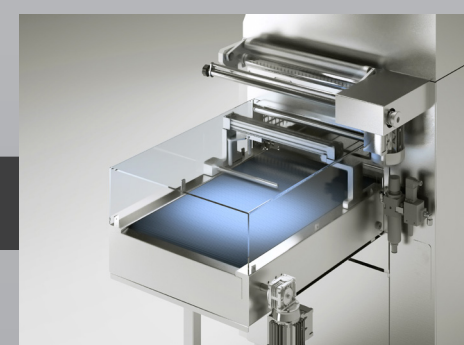

Nastro motorizzato in uscita con possibilità di convogliare più file in una singola per pesatura etichettatura e controllo metal detector.

Motorized outfeed conveyor allows for the channeling of multiple tray lines into a single tray line for weighing, labelling and metal detection.



Sistemi automatici di dosaggio per prodotti solidi, liquidi e granulari.

Automatic dosing of solids, liquids and granules.

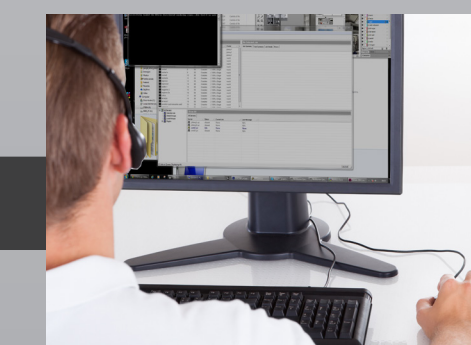

Teleassistenza remota tramite modem industriale.

Remote tele-assistance via the company modem.