

COTSWOLD MECHANICAL LTD

CMW 3000 Series

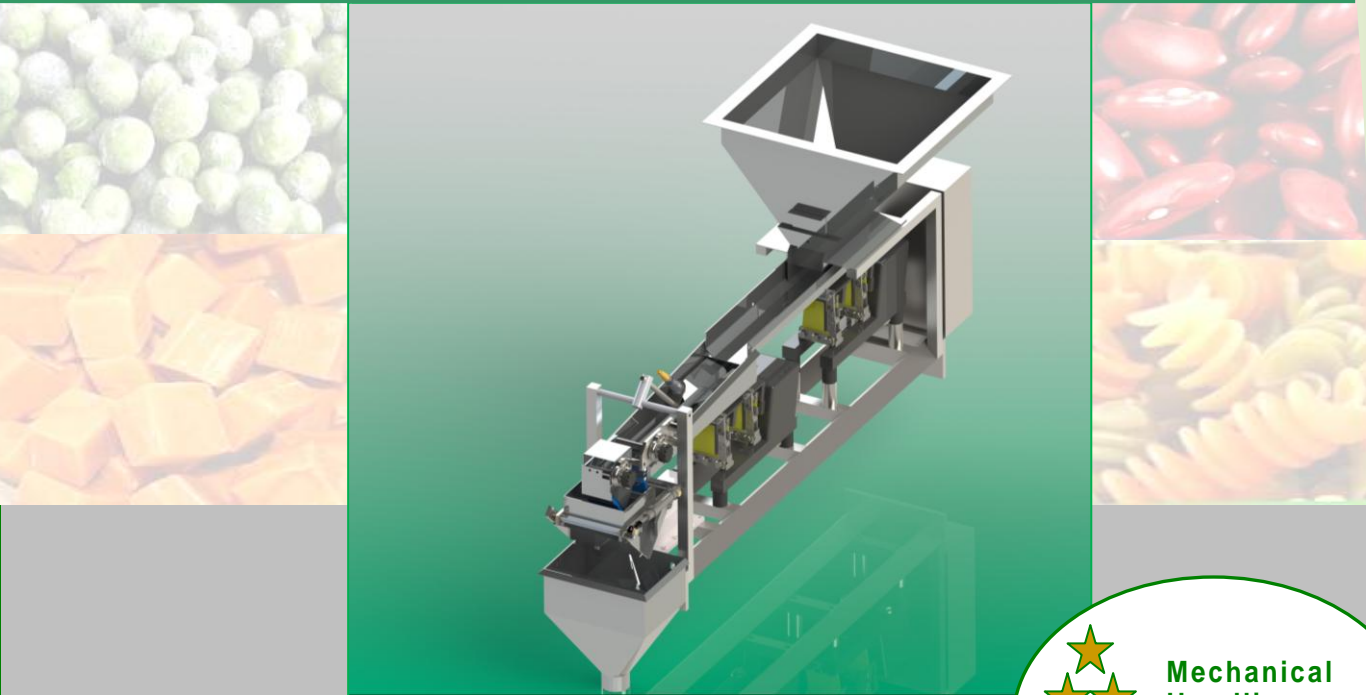

**Mechanical
Handling,
Weighing and
Counting**

CMW 3000 Series Main Features

- Micro Processor Control System, with 100 Product Memory
- Precision Weighing System
- Latest Technology Control System
- Stainless Steel Construction
- Stainless Steel Contact Parts in Mirror Polished, Rigidised 304 or 316
- Automatic and Manual Systems
- Weight Range 1g to 250 g
- Speed: Up To 15 Weighing's per Minute
- Integral interface signals to control both upstream and downstream equipment

COTSWOLD MECHANICAL LTD

Unit 4, Chancel Close, Eastern Avenue, Gloucester, GL4 3SN

TEL: (01452) 309944

FAX: (01452) 306644

<http://www.cotsmech.co.uk>

Email: enquiries@cotsmech.co.uk

COTSWOLD MECHANICAL CMW 3000

COTSWOLD MECHANICAL LTD

CMW 3000 Series

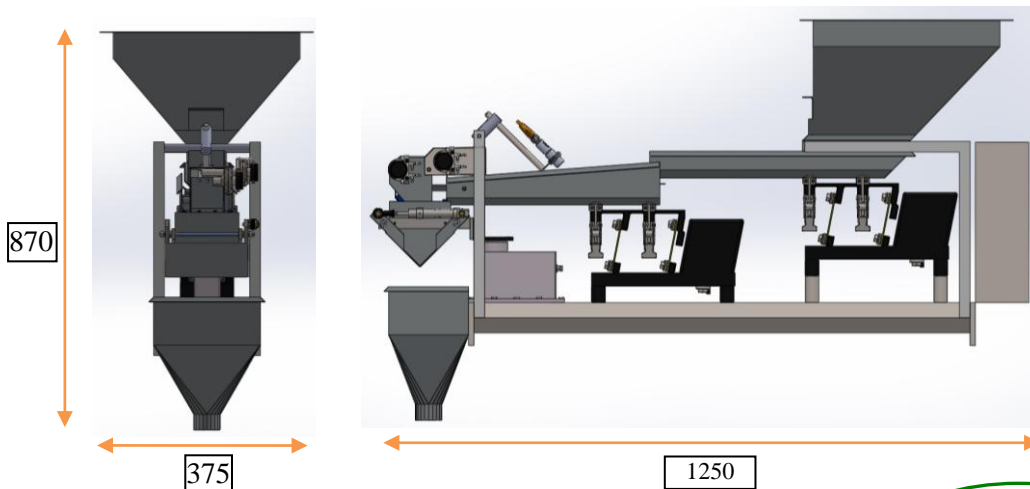

**Mechanical
Handling,
Weighing and
Counting**

CMW3000	(Typical Machine)
Power Requirements	230 Vac 1 Phase 50 Hz 5 Amp 1100 w – 1 Kw – 1 kVA.
Air Consumption	Approximately 15 Litres per Minute @ 5 Bar (60 PSI)
Approximate Dimensions	L 1250mm W 375mm H 870mm
Weight	65 Kg

The majority of food contact parts of all weighing machines have been designed and built in Grade 304/316, Food Quality Stainless Steel. Their construction is such that all seam welds are continuous, crevice free & dressed clean to eliminate product retention. Gating contact parts are of FDA Approved, FQ Nitrile Rubber construction.

Furthermore, the machinery is designed & built wherever possible in accordance with:

The following transposed harmonised European standards

Machinery Directive 2006/42/EC and the protection requirements of the Electromagnetic Compatibility Directive 2004/108/EC

BS EN ISO 12100-1:2003 safety of machinery – basic concepts, general principles for design.

BS EN ISO 13857, safety of machinery – safety distances to prevent danger zones being reached by the upper limbs

EN349:1993+A1 2008 safety of machinery – minimum gaps to avoid crushing of parts of the body

EN13850:2005 + BS EN 60947-5-5 safety of machinery – emergency stop equipment, functional aspects – principles for design

BS EN 60204-1:2006 + A1 2009 safety of machinery – electrical equipment of machines – specification for general requirements

NEN-IEC-IEC 61000-6-1: 2001:Generic Emissions standard and Generic Immunity standard:

Industrial environments

In addition this machinery has been designed and manufactured in accordance with:

British Standard PD 5304:2005 Safety of Machinery

The Plastics Materials and Articles in contact with Food Regulations 2011

COTSWOLD MECHANICAL LTD

Unit 4, Chancel Close, Eastern Avenue, Gloucester, GL4 3SN

TEL: (01452) 309944

FAX: (01452) 306644

<http://www.cotsmech.co.uk>

Email: enquiries@cotsmech.co.uk

COTSWOLD MECHANICAL CMW 3000